

4-1/2" AMERICAN-DARLING® MARK 73-5 FIRE HYDRANT
BY AMERICAN FLOW CONTROL®



AMERICAN

FLOW CONTROL

THE RIGHT WAY

CONSTRUCTION

Fully complies with ANSI/AWWA C502 and is available UL Listed and FM Approved in applicable configurations.

ONE-PIECE BRONZE OPERATING NUT

Has a removable pipe plug to allow lubrication of operating threads.

TRAVEL STOP NUT

Provides a positive limit to main rod travel and eliminates rod buckling by eliminating contact of valve bottom with interior of base, thereby protecting coating.

HYDRANT ROD

Furnished in two sections of high-tensile steel. Upper section has bronze sleeve where it passes through housing O-rings. Upper and lower sections are connected by gray iron coupling using stainless steel pins.

EPOXY PRIMER AND POLYURETHANE COATING SYSTEM

Upper barrel is provided with an E-coat primer and a two-part polyurethane top coat for improved durability, color and gloss retention.

STAINLESS STEEL HYDRANT SPRING

Assures drain closure after approximately three turns.

DRAIN LEVER

Rugged bronze lever performs dual function as carrier for drain lever pads and as wrench to remove working parts.

BASE BOLTS AND NUTS

Hydrant is provided with stainless steel fasteners below grade.

HYDRANT SEAT

Seat is constructed of bronze. Design includes a near-vertical machined seating surface with two drain ports.

HYDRANT VALVE

Consists of an epoxy-coated iron valve top and bottom. Hydrant valve rubber constructed of EPDM rubber. Valve has a near-vertical seat taper to minimize entrapment of debris while sealing against an all-bronze hydrant seat. Spherical design provides minimal flow loss.

WEATHER COVER

The word "OPEN" and an arrow show direction to turn the operating nut. The rubber weather shield helps prevent water and debris from entering the housing area.

HOUSING AND HOUSING COVER

Retain operating nut and thrust washer. Rugged construction helps withstand operating forces.

THRUST WASHER

Takes upward thrust when opening hydrant valve and reduces operating torque.

NOZZLES

Patented design allows field replacement of damaged nozzles in minutes by one person. Does not utilize a threaded barrel, pins or set screws which can become dislodged or lost.

UPPER BARREL

Ductile iron with markings identifying size, model and year of manufacture.

TRAFFIC FEATURE

Upper barrel is connected to lower barrel with breakable traffic flange and eight bolts and nuts. This feature allows 360° rotation of upper barrel.

LOWER BARREL

The ductile iron lower barrel provides extra strength against traffic impact damage.

HYDRANT DRAIN RING

Drain ring is securely held between barrel and base flange, provides bronze-to-bronze threaded connection for hydrant seat. Hydrant is equipped with four drain outlets.

BASE

Spherical-shaped base has no projections or cavities to obstruct flow. Base is epoxy-coated ductile iron.

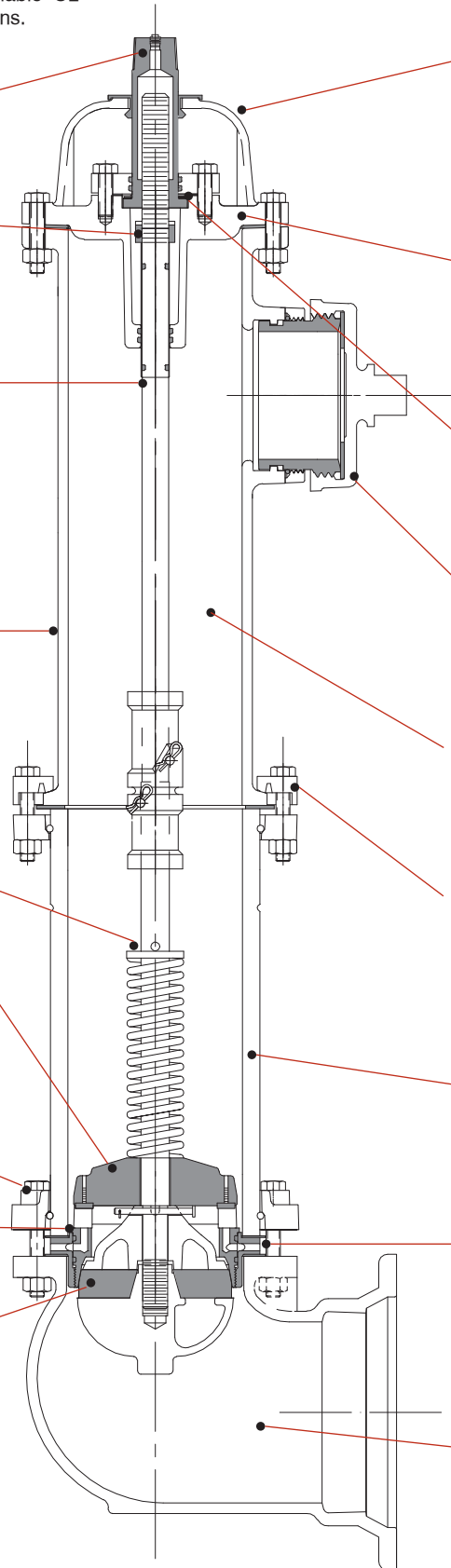

EXPLODED DRAWINGS

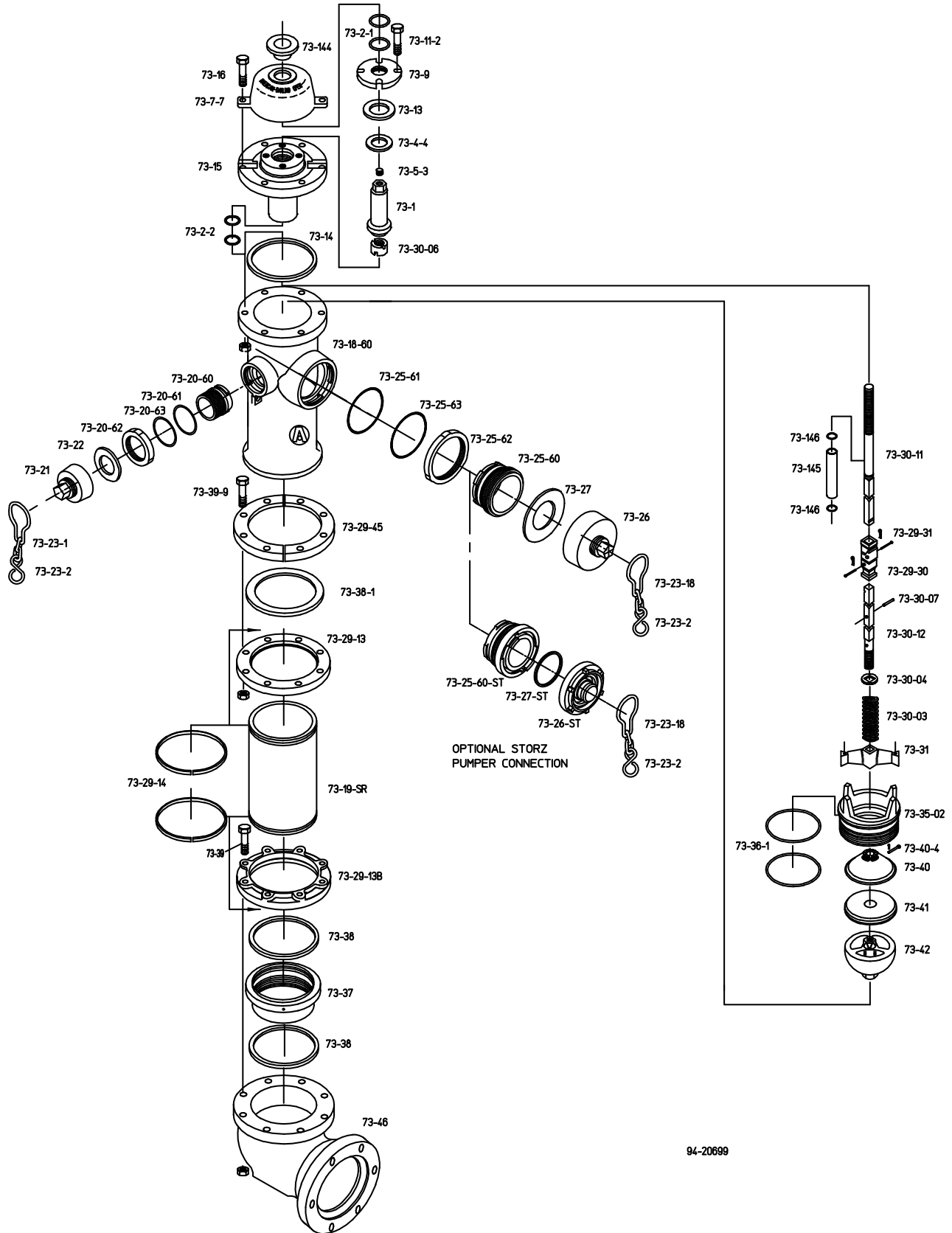

4-1/2" AMERICAN-DARLING MARK 73-5 FIRE HYDRANT

PARTS LIST

REF NO.	QTY.	DESCRIPTION	MATERIAL
73-1	1	Operating Nut	Bronze
73-2-1	2	Cover O-ring	Buna-N
73-2-2	2	Housing O-ring	Buna-N
73-4-4	1	Thrust Washer	Nylatron
73-5-3	1	Pipe Plug	Stainless Steel
73-7-7	1	Weather Cover	Gray Iron
73-9	1	Housing Cover	Gray Iron
73-11-2	4	Housing Cover Cap Screw	Plated Steel
73-13	1	Housing Cover Gasket	Fiber
73-14	1	Housing Gasket	Rubber
73-15	1	Housing	Ductile Iron
73-16	6	Housing Bolt and Nut	Plated Steel
73-18-60	1	Upper Barrel	Ductile Iron
73-19-SR	1	Lower Barrel	Ductile Iron
73-20-60	2	Hose Nozzle	Bronze
73-20-61	2	Hose Nozzle Seal	Buna-N
73-20-62	2	Hose Nozzle Retainer	Ductile Iron
73-20-63	2	Hose Nozzle Retainer Washer	Teflon
73-21	2	Hose Cap	See Note 7
73-22	2	Hose Cap Gasket	Rubber
73-23-1	1	Hose Cap Chain	Steel
73-23-2	3	S-Hook	Steel
73-23-18	1	Pumper Cap Chain	Steel
73-25-60	1	Pumper Nozzle	Bronze
73-25-60-ST	1	Storz Nozzle	Bronze/Aluminum
73-25-61	1	Pumper Nozzle Seal	Buna-N
73-25-62	1	Pumper Nozzle Retainer	Ductile Iron
73-25-63	1	Pumper Nozzle Retainer Washer	Teflon
73-26	1	Pumper Cap	See Note 7
73-26-ST	1	Storz Nozzle Cap	Aluminum
73-27	1	Pumper Cap Gasket	Rubber
73-27-ST	1	Storz Cap Gasket	Rubber
73-29-13	1	Barrel Flange	Ductile Iron
73-29-13B	1	Base Flange	Ductile Iron
73-29-14	2	Snap Ring	Stainless Steel
73-29-30	1	Rod Coupling	Gray Iron
73-29-31	2	Coupling & Clip Pins	Stainless Steel
73-29-45	1	2-Piece Breakable Flange	Gray Iron
73-30-03	1	Hydrant Spring	Stainless Steel
73-30-04	1	Spring Plate	Stainless Steel
73-30-06	1	Travel Stop Nut	Bronze
73-30-07	1	Spring Plate Pin	Stainless Steel
73-30-11	1	Upper Hydrant Rod	Steel
73-30-12	1	Lower Hydrant Rod	Steel
73-31	1	Drain Lever	Bronze
73-35-02	1	Hydrant Seat	Bronze
73-36-1	2	Seat O-ring	Buna-N
73-37	1	Drain Ring	Bronze
73-38	2	Drain Ring Gasket	Composition Rubber
73-38-1	1	Barrel Gasket	Rubber
73-39	8	Base Bolt and Nut	Stainless Steel
73-39-9	8	Barrel Bolt and Nut	Plated Steel
73-40	1	Hydrant Valve Top	Ductile Iron
73-40-4	1	Clevis & Clip Pin	Stainless Steel
73-41	1	Hydrant Valve	EPDM Rubber
73-42	1	Hydrant Valve Bottom	Ductile Iron
73-46-2	1	Flanged Base	Ductile Iron
73-46-5	1	Mechanical Joint Base	Ductile Iron
73-46-TY	1	Tyton® Base	Ductile Iron
76-46-AA	1	ALPHA™ Base	Ductile Iron
73-144	1	Weather Shield	Rubber
73-145	1	Rod Sleeve	Bronze
73-146	2	Sleeve O-ring	Buna-N

NOTES

1. Size and shape of nut on operating nut and cap, threading on nozzles and caps, and the direction of opening made to specifications.
2. Cap chains are not furnished unless specified.
3. Working pressure 250 psig, test pressure 500 psig.
4. Hydrant conforms to ANSI/AWWA C502 standard.
5. Upper barrel can be rotated 360°.
6. UL Listed and FM Approved in allowable configurations.
7. National Standard and other common cap configurations are constructed of ductile iron. Other offerings may be constructed of gray cast iron.
8. Nominal turns to open is 19-1/2.
9. TYTON® is a registered trademark of United States Pipe and Foundry Co., LLC.
10. ALPHA™ is a licensed trademark of Romac Industries, Inc. (U.S. Patent 8,894,100)

AMERICAN Flow Control strongly recommends that you follow routine maintenance on fire hydrants as outlined in AWWA Manual M-17 for Installation, Field Testing and Maintenance of Fire Hydrants. The ease of operation and the frequency of repair depends on the condition of the water system and the maintenance given. Dirt, gravel and other foreign material in the hydrant may prevent it from closing or draining properly, which may result in damage to the hydrant main valve. Under most operating conditions AMERICAN Flow Control recommends semiannual lubrication and inspection of fire hydrants.

FEATURES

The 4-1/2" American-Darling Mark 73-5 fire hydrant by AMERICAN Flow Control® incorporates more than 100 years of experience in design, manufacture and field experience. This means dependable and efficient operation when needed.

Introduced in 1973, the 4-1/2" American-Darling Mark 73-5 hydrant is rated at 250 psig and is tested at 500 psig. This hydrant meets or exceeds all requirements of ANSI/AWWA C502 for dry-barrel hydrants.

The 4-1/2" American Darling Mark 73-5 is manufactured with the features you expect from a high-quality fire hydrant. The all-bronze seat and drain ring ensure that the Mark 73-5 hydrant is easily serviced by just one person.

The 4-1/2" American-Darling Mark 73-5 fire hydrant is Certified to NSF/ANSI/CAN 61 and NSF/ANSI/CAN 372, which exhibit compliance with U.S Safe Drinking Water Act.

UL-FM

In applicable configurations, the 4-1/2 " American-Darling Mark 73-5 hydrant is UL Listed and FM Approved. Both UL and FM Approvals require that we consistently manufacture and test our hydrants in full compliance with their stringent standards. Our facilities are subject to periodic inspections to ensure we are in compliance with their standards.

4-1/2" American-Darling Mark 73-5 Standard Features:

- Upper barrel is furnished with an E-coat primer and a two-part polyurethane top coat for durability, gloss and color retention
- Ductile iron upper barrel, lower barrel, base and housing
- Easy 360° rotation of nozzle section
- 250 psig rated working pressure
- Tested at 500 psig
- Lubrication chamber
- Stainless steel bolting below grade
- Bronze-to-bronze seating
- Short, lightweight disassembly wrench
- Travel stop nut located in top of hydrant
- Positive compression, fast closing drains

BENEFITS

Spring-Loaded Multiport Drains

Four external drain outlets are standard on the 4-1/2" American-Darling Mark 73-5. The stainless steel rod spring helps assure drains close after approximately three turns of the operating nut. This important feature helps prevent washouts and erosion by reducing the duration that drain valve is open during operation.

Near Vertical Hydrant Valve

Minimal taper on the 4 1/2 in. American-Darling Mark 73-5 hydrant valve helps prevent entrapment of debris in the hydrant seating area.

Lubrication Chamber

Seals operating threads from water and debris. Proper maintenance is required.

Top Travel Stop Nut

Stop nut in the housing limits opening. This helps prevent rod buckling and damage to bronze components that may occur if excessive torque is applied in the full open position. This also protects interior base coating by preventing valve bottom from contacting base.

SPECIFICATIONS

Fire hydrants shall meet or exceed ANSI/AWWA C502, latest revision. Rated working pressure shall be 250 psig, test pressure shall be 500 psig and hydrants shall include the following specific design criteria:

The main valve closure shall be of the compression type. Traffic feature to be designed for easy 360° rotation of nozzle section during field installation.

The main valve opening shall not be less than 4-1/2" and be designed so that removal of all working parts can be accomplished without excavating. The hydrant valve shall be constructed of EPDM rubber and have a vertical taper of 20° or less. The bronze seat shall be threaded into a bronze drain ring. The draining system of the hydrant shall be bronze and positively activated by the main operating rod. Hydrant drains shall close completely after no more than three turns of the operating nut. There shall be a minimum of two internal ports and four outlets to the exterior of the hydrant. Drain shutoff to be by direct compression closure. Sliding drains are not permitted.

Hydrant barrels shall be made of ductile iron. Nozzles shall be retained by collars. Threaded-in nozzles and nozzles using set screws are not allowed.

Hydrant upper barrel shall be factory coated with Electrodeposition (E-coat) epoxy primer and catalyzed two-part polyurethane top coating. Base shall be coated with fusion-bonded epoxy. All bolting below grade shall be 304 stainless steel.

Hydrants shall be UL Listed and FM Approved in applicable configurations. All hydrants are to be certified to NSF/ANSI/CAN 61 and NSF/ANSI/CAN 372.

Hydrants shall be equal to the 4-1/2" American-Darling® Mark 73-5 by AMERICAN Flow Control®.



AMERICAN

FLOW CONTROL

THE RIGHT WAY

AMERICAN Flow Control

P.O. Box 2727
Birmingham, AL 35202-2727
Phone: 800-326-8051
Fax: 800-610-3569
E-mail: afcsales@american-usa.com

Waterous Company

125 Hardman Avenue South
South St. Paul, MN 55075-2421
Phone: 888-266-3686
Fax: 800-601-2809
E-mail: afcsales@american-usa.com

WWW.AMERICAN-USA.COM

Distributed By:



Mark 73-5 Product Information

Product literature may become outdated. AMERICAN is not responsible for out-of-date information, errors or omissions.
Please contact AMERICAN for the most current product information.

wasda

EOE/Vets/Disabilities

Revised 9/30/21