

# OPERATION AND MAINTENANCE MANUAL

## SERIES 2800 TAPPING SLEEVES



# AMERICAN

FLOW CONTROL

**THE RIGHT WAY**

# INDEX

## SERIES 2800 TAPPING SLEEVES



	<b>PAGE</b>
<b>INTRODUCTION</b> .....	6A-2
<b>FEATURES AND SPECIFICATIONS</b> .....	6A-3
<b>ORDERING</b>	
Dimensions:	
Series 2800-C (4"–12" & 16" Sizes).....	6A-4, 6A-5
Series 2800-C (16" x 16" Size).....	6A-6, 6A-7
Series 2800-C (14" & 18" - 24" Sizes).....	6A-8, 6A-9
Series 2800-A (4"–12" Sizes).....	6A-10, 6A-11
Weights:	
Series 2800.....	6A-12
Submittal Sheet.....	6A-13
<b>INSTALLATION</b>	
Series 2800.....	6A-14, 6A-15, 6A-16
<b>REPAIRS</b>	
Parts Lists:	
Series 2800-C (4"–12" & 16" Sizes).....	6A-17
Series 2800-C (16" x 16" Size).....	6A-18
Series 2800-C (14" & 18" - 24" Sizes).....	6A-19
Series 2800-A (4"–12" Sizes).....	6A-20



## TAPPING SLEEVES

AMERICAN Flow Control offers ductile iron tapping sleeves in sizes 4in. x 4in.–24in. x 24in. AMERICAN Flow Control tapping sleeves are designed to provide a safe, efficient means of connecting branch piping to existing lines.

## SERIES 2800 - FEATURES AND SPECIFICATIONS



### Features

AMERICAN Flow Control offers ductile iron tapping sleeves in sizes 4 in. x 4 in. - 24 in. x 24 in.

AMERICAN Flow Control tapping sleeves are designed to provide a safe, efficient means of connecting branch piping to existing lines.

### Tapping Sleeves

The Series 2800 Compact Ductile Iron Tapping Sleeves are available in sizes 4 in. x 4 in. - 24 in. x 24 in. with mechanical joint ends for use on ductile iron pipe and 4 in. x 4 in. - 12 in. x 12 in. for use on Asbestos Cement (A-C) pipe.

The Series 2800 sleeves feature full length, heavy duty, ductile iron construction. Their compact construction makes them lighter and easier to handle. Since they are made of ductile iron, they have twice the strength of gray iron sleeves.

### Specifications

Tapping sleeves shall be of ductile iron construction meeting ASTM A536. Side flange seals shall be O-ring type of either round, oval or rectangular cross-sectional shape.

All sleeves to include the end joint accessories and split glands necessary to assemble sleeve to pipe.

No special tools are required other than a standard socket wrench.

Flange end pilot dimensions to be in compliance with MSS-SP-60.

# SERIES 2800-C DIMENSIONS, 4" - 12" & 16" SIZES FOR USE WITH GRAY IRON OR DUCTILE IRON PIPE

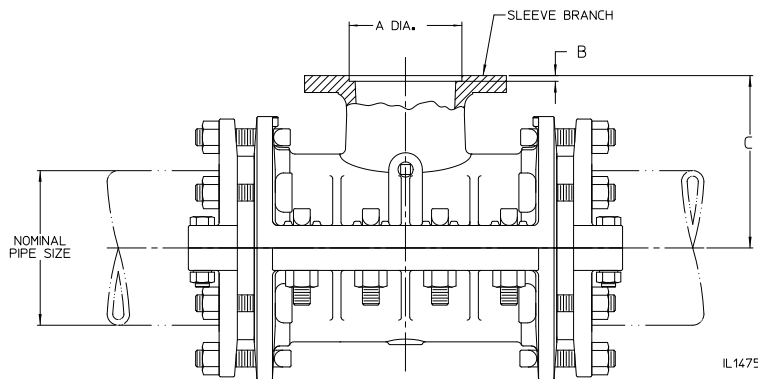
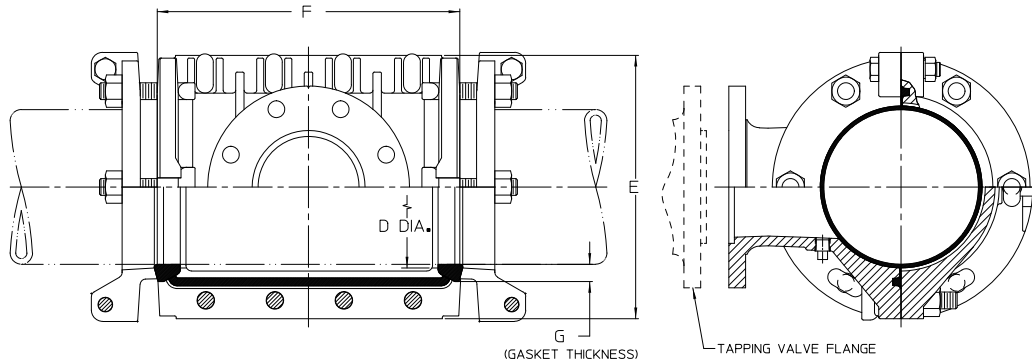

### Identification Marking on Sleeve

#### Sleeve Size

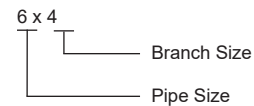

#### Sleeve Model No.

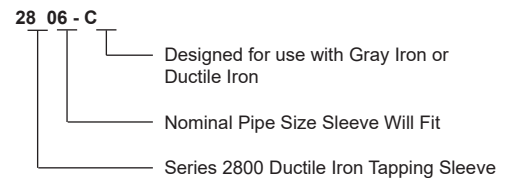

Sleeve Size (Pipe x Branch)	4x4	6x4	6X6	8X4	8X6	8X8	10X4	10X6	10x8	10x10
A Diameter (+.031 -.000)	5.016	5.016	7.016	5.016	7.016	9.016	5.016	7.016	9.016	11.016
B	.25	.25	.31	.25	.31	.31	.25	.31	.31	.31
C	6.38	7.75	7.88	9.00	9.06	9.00	10.38	10.63	10.88	10.88
D Diameter	5.13	7.22	7.22	9.44	9.44	9.44	11.53	11.53	11.53	11.53
E	9.63	11.75	11.75	13.88	13.88	13.88	16.63	16.63	16.63	16.63
F	10.88	13.50	13.50	15.00	15.00	15.00	16.75	16.75	16.75	16.75

Sleeve Size (Pipe x Branch)	12x4	12X6	12X8	12X10	12X12	16X4	16X6	16X8	16X10	16X12
A Diameter (+.031 -.000)	5.016	7.016	9.016	11.016	13.016	5.016	7.016	9.016	11.016	13.016
B	.25	.31	.31	.31	.31	.25	.31	.31	.31	.31
C	11.38	11.63	11.88	11.94	12.88	13.63	14.13	14.50	14.88	14.88
D Diameter	13.63	13.63	13.63	13.63	13.63	17.97	17.97	17.97	17.97	17.97
E	18.50	18.50	18.50	18.50	18.50	23.50	23.50	23.50	23.50	23.50
F	19.50	19.50	19.50	19.50	19.50	22.50	22.50	22.50	22.50	22.50

G (Gasket Thickness) - Two 3/4 in. thick gaskets that fit ductile iron and centrifugally cast gray iron pipe are supplied, or alternatively two 5/8 in. thick gaskets should be used for pit cast pipe. If there is a doubt about which type of pipe the sleeve will be used with, order 5/8 in. thick gaskets in addition to the 3/4 in. thick gaskets. See table on next page for the range of pipe sizes with which each gasket can be used.

### NOTES:

1. 250 psig rated working pressure.
2. Flange pilot dimensions (A & B) are in accordance with MSS SP-60.

**SERIES 2800-C DIMENSIONS, 4" - 12" & 16" SIZES  
FOR USE WITH GRAY IRON OR DUCTILE IRON PIPE**

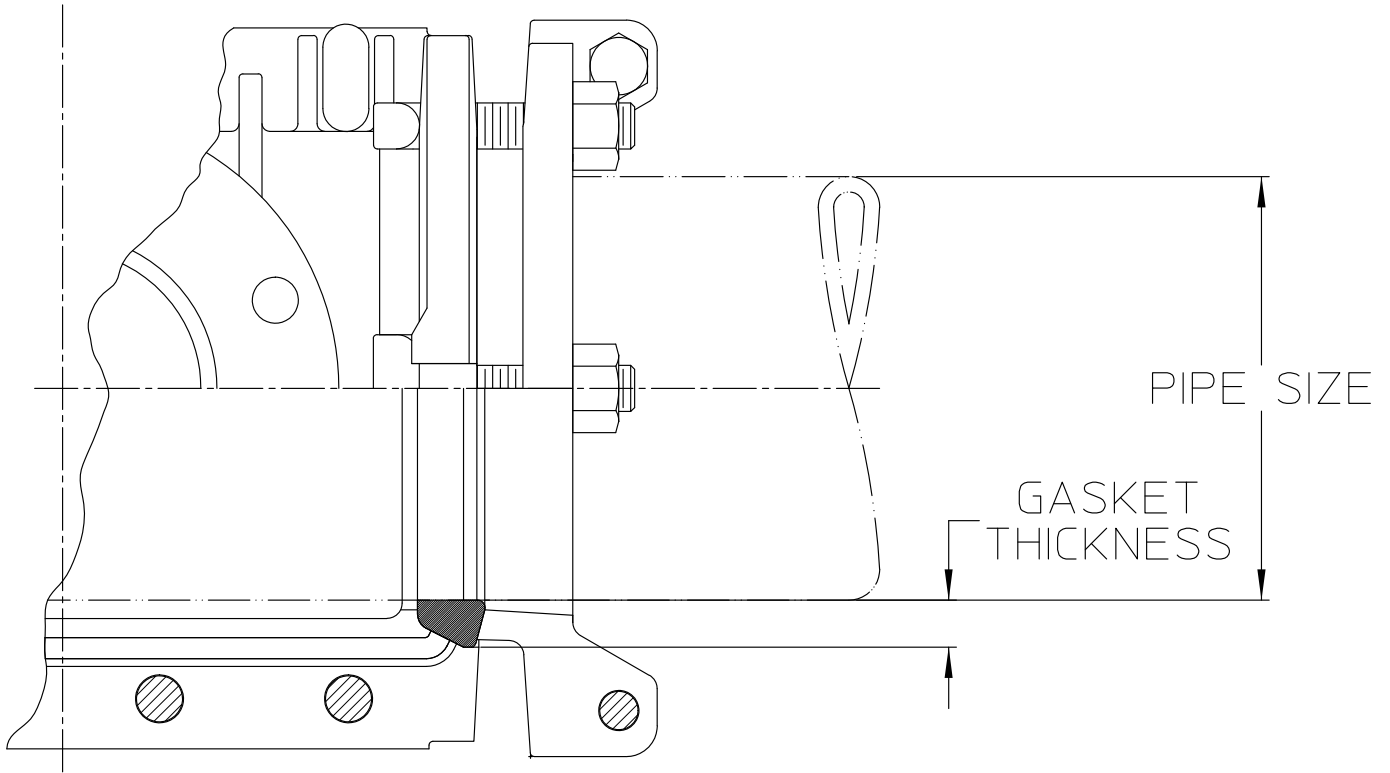

IL1475-2

Nominal Pipe Size	3/4 in. Thick Gasket				5/8 in. Thick Gasket			
	Diameter		Circumference		Diameter		Circumference	
	Minimum	Maximum	Minimum	Maximum	Minimum	Maximum	Minimum	Maximum
4"	4.74	4.86	14.88	15.25	4.86	5.06	15.25	15.88
6"	6.84	6.96	21.50	21.88	6.96	7.16	21.88	22.50
8"	8.99	9.11	28.25	28.62	9.11	9.37	28.62	29.44
10"	11.04	11.16	34.69	35.06	11.16	11.44	35.06	35.31
12"	13.14	13.26	41.31	41.69	13.26	13.53	41.69	42.50
16"	17.34	17.46	54.50	54.88	17.46	17.87	54.88	56.12

**SERIES 2800-C DIMENSIONS, 16"x16" SIZE  
FOR USE WITH GRAY IRON OR DUCTILE IRON PIPE**

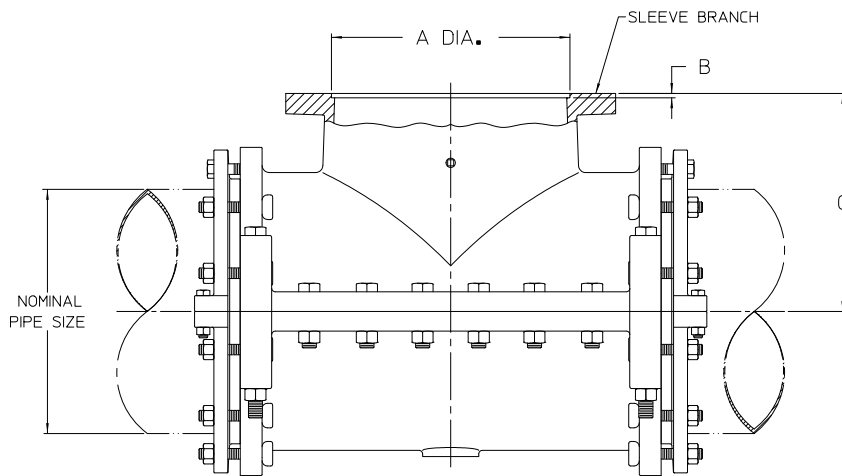
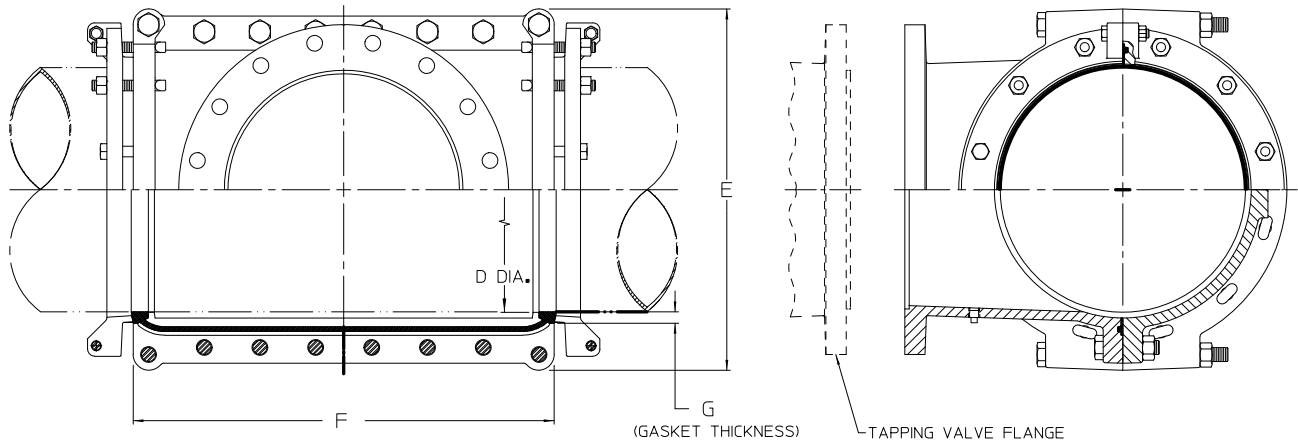

IL1475-4

**Identification Marking on Sleeve**

**Sleeve Size**

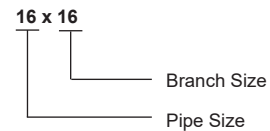

**Sleeve Model No.**

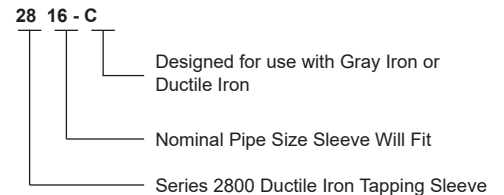

Sleeve Size (Pipe x Branch)	16x16
A Diameter (+.031 -.000)	17.020
B	.31
C	15.50
D Diameter	17.97
E	25.75
F	30.00

G (Gasket Thickness) - Two 3/4 in. thick gaskets that fit ductile iron and centrifugally cast gray iron pipe are supplied, or alternatively two 5/8 in. thick gaskets should be used for pit cast pipe. If there is a doubt about which type of pipe the sleeve will be used with, order 5/8 in. thick gaskets in addition to the 3/4 in. thick gaskets. See table on next page for the range of pipe sizes with which each gasket can be used.

**NOTES:**

1. 250 psig rated working pressure.
2. Flange pilot dimensions (A & B) are in accordance with MSS SP-60.

**SERIES 2800-C DIMENSIONS, 16"x16" SIZE  
FOR USE WITH GRAY IRON OR DUCTILE IRON PIPE**

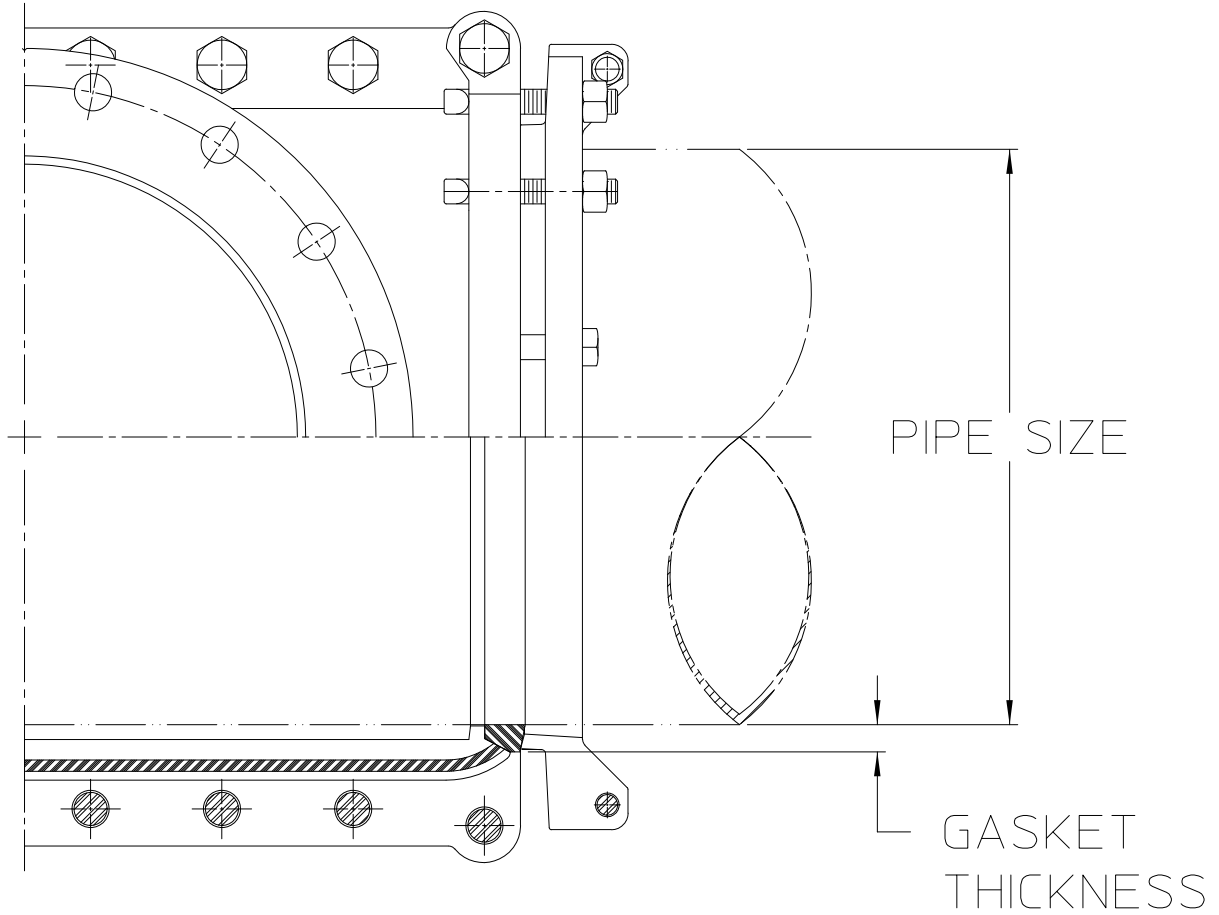

IL1475-5

Nominal Pipe Size	3/4 in. Thick Gasket				5/8 in. Thick Gasket			
	Diameter		Circumference		Diameter		Circumference	
	Minimum	Maximum	Minimum	Maximum	Minimum	Maximum	Minimum	Maximum
16"	17.34	17.46	54.50	54.88	17.46	17.87	54.88	56.12



## SERIES 2800-C DIMENSIONS, 14" & 18"-24" SIZES FOR USE WITH GRAY IRON OR DUCTILE IRON PIPE

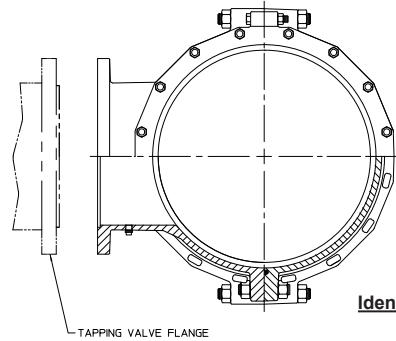
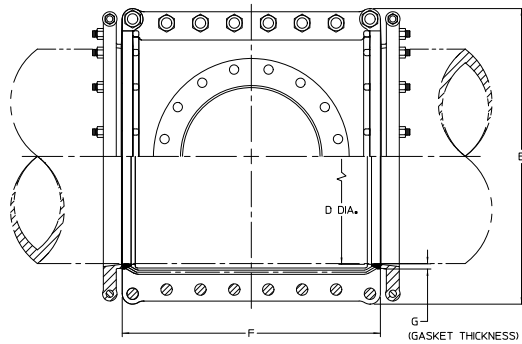

**Identification Marking on Sleeve**

**Sleeve Size**

**14 x 4**

Branch Size

Pipe Size

**Sleeve Model No.**

**28 14 - C**

Designed for use with Gray Iron or Ductile Iron

Nominal Pipe Size Sleeve Will Fit

Series 2800 Ductile Iron Tapping Sleeve

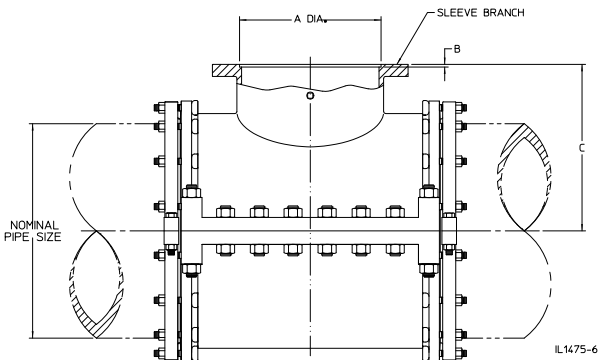

Sleeve Size (Pipe x Branch)	14x4	14x6	14X8	14X10	14X12	14X14	18X4	18X6	18X8	18x10	18x12
A Diameter (+.031 -.000)	5.016	7.016	9.016	11.016	13.016	15.016	5.016	7.016	9.016	11.016	13.016
B	.25	.31	.31	.31	.31	.31	.25	.31	.31	.31	.31
C	13.50	13.50	13.50	13.50	13.50	13.50	15.50	15.50	15.50	15.50	16.00
D Diameter	15.44	15.44	15.44	15.44	15.44	15.44	19.63	19.63	19.63	19.63	19.63
E	23.00	23.00	23.00	23.00	23.00	23.00	28.00	28.00	28.00	28.00	28.00
F	24.00	24.00	24.00	24.00	27.00	27.00	18.00	18.00	24.00	24.00	24.00

Sleeve Size (Pipe x Branch)	18x14	18x16	18X18	20X4	20X6	20X8	20X10	20X12	20X14	20x16	20x18
A Diameter (+.031 -.000)	15.016	17.016	19.016	5.016	7.016	9.016	11.016	13.016	15.016	17.016	19.016
B	.31	.31	.31	.25	.31	.31	.31	.31	.31	.31	.31
C	16.00	16.00	16.00	17.25	17.25	17.25	17.25	17.25	17.25	17.75	17.75
D Diameter	19.63	19.63	19.63	21.75	21.75	21.75	21.75	21.75	21.75	21.75	21.75
E	28.00	28.00	28.00	30.25	30.25	30.25	30.25	30.25	30.25	30.25	30.25
F	31.00	31.00	31.00	24.00	24.00	24.00	24.00	24.00	30.00	30.00	34.00

Sleeve Size (Pipe x Branch)	20x20	24x4	24X6	24X8	24X10	24X12	24X14	24X16	24X18	24x20	24x24
A Diameter (+.031 -.000)	21.016	5.016	7.016	9.016	11.016	13.016	15.016	17.016	19.016	21.016	25.016
B	.31	.25	.31	.31	.31	.31	.31	.31	.31	.31	.31
C	17.75	19.00	19.00	19.00	19.00	19.00	19.00	20.00	20.00	20.00	20.00
D Diameter	21.75	25.94	25.94	25.94	25.94	25.94	25.94	25.94	25.94	25.94	25.94
E	30.25	35.50	35.50	35.50	35.50	35.50	35.50	35.50	35.50	35.50	35.50
F	34.00	18.00	18.00	25.00	25.00	25.00	31.00	31.00	31.00	38.00	38.00

G (Gasket Thickness) - Two 3/4 in. thick gaskets that fit ductile iron and centrifugally cast gray iron pipe are supplied. See table on next page for the minimum and maximum allowable pipe sizes..

**NOTES:**

1. 250 psig rated working pressure.
2. Flange pilot dimensions (A & B) are in accordance with MSS SP-60.

**SERIES 2800-C DIMENSIONS, 14" & 18"-24" SIZES  
FOR USE WITH GRAY IRON OR DUCTILE IRON PIPE**

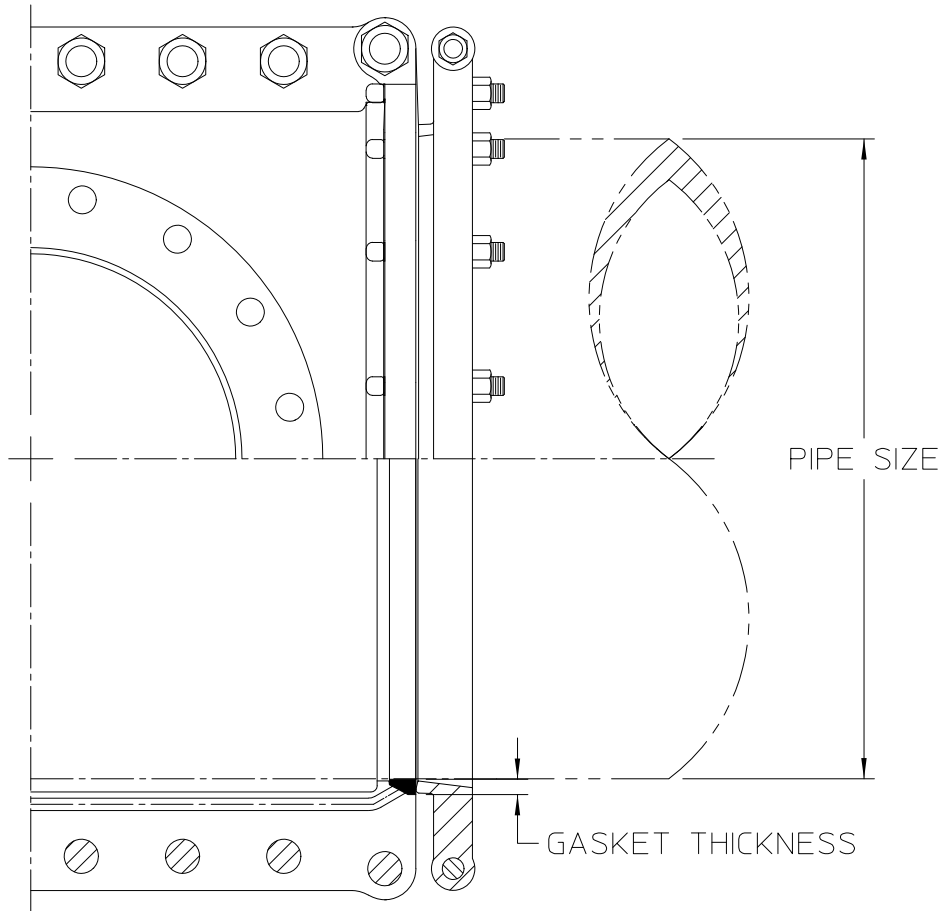

IL1475-7

Nominal Pipe Size	3/4 in. Thick Gasket			
	Diameter		Circumference	
	Minimum	Maximum	Minimum	Maximum
14"	15.24	15.36	47.88	48.25
18"	19.44	19.56	61.07	61.45
20"	21.54	21.66	67.67	68.05
24"	25.74	25.86	80.86	81.24

**SERIES 2800-A DIMENSIONS, 4" - 12" SIZES  
FOR USE WITH ASBESTOS-CEMENT (A-C) PIPE**

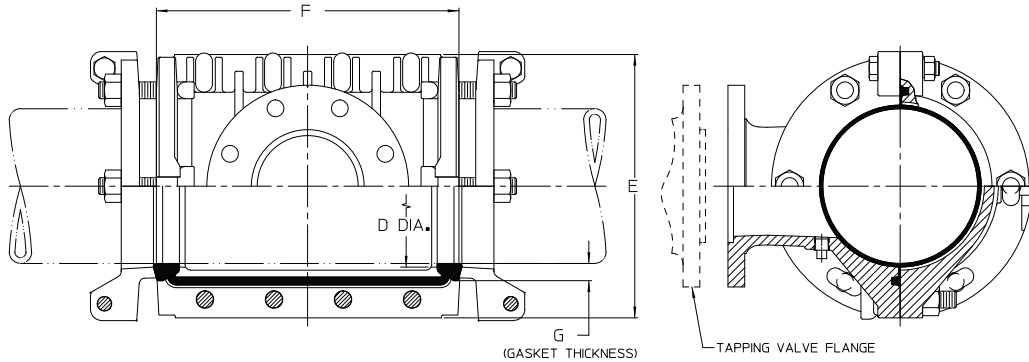

**Identification Marking on Sleeve**

**Sleeve Size**

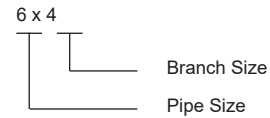

**Sleeve Model No.**

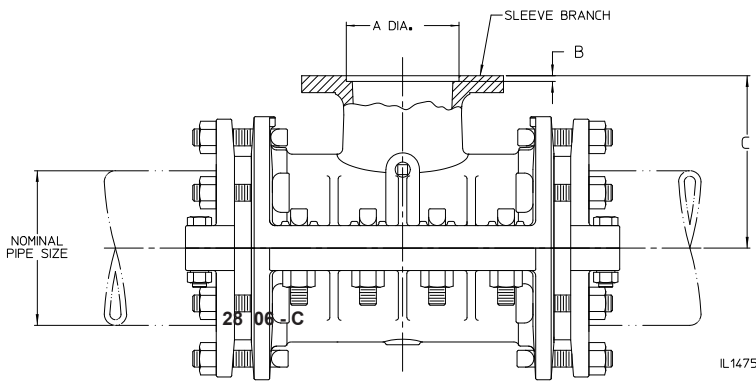
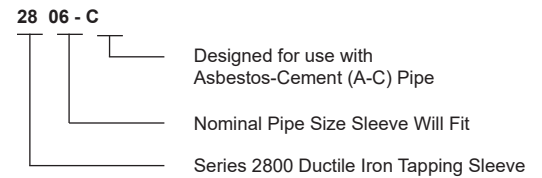

IL1475

Sleeve Size (Pipe x Branch)	4x4	6x4	6X6	8X4	8X6	8X8	10X4	10X6	10x8	10x10	12x4	12x6	12x8	12x10	12x12
A Diameter (+.031 -.000)	5.016	5.016	7.016	5.016	7.016	9.016	5.016	7.016	9.016	11.016	5.016	7.016	9.016	11.016	13.016
B	.25	.25	.31	.25	.31	.31	.25	.31	.31	.31	.31	.31	.31	.31	.31
C	6.62	7.88	8.00	9.12	9.25	9.25	10.62	10.88	11.12	11.12	11.75	12.00	12.31	12.38	13.25
D Diameter	5.59	7.62	7.62	9.81	9.81	9/81	12.12	12.12	12.12	12.12	14.53	14.53	14.53	14.53	14.53
E	9.88	12.12	12.12	14.25	14.25	14.25	17.00	17.00	17.00	17.00	19.25	19.25	19.25	19.25	19.25
F	10.88	13.50	13.50	15.00	15.00	15.00	16.88	16.88	16.88	16.88	19.50	19.50	19.50	19.50	19.50

**G** (Gasket Thickness) - Two duck tip (3/4 in. thick) and two plain tip (5/8 in. thick) MJ end gaskets are supplied with each sleeve. See next page for range of pipe sizes each type will fit.

**NOTES:**

1. 200 psig rated working pressure.
2. Flange pilot dimensions (A & B) are in accordance with MSS SP-60.

**SERIES 2800-A DIMENSIONS, 4" - 12" SIZES  
FOR USE WITH ASBESTOS-CEMENT (A-C) PIPE**



Two 3/4 in. thick duck tip and two 5/8 in. thick plain tip MJ end gaskets are supplied with each sleeve. The A-C pipe is to be measured to determine which size gasket is used in the installation.

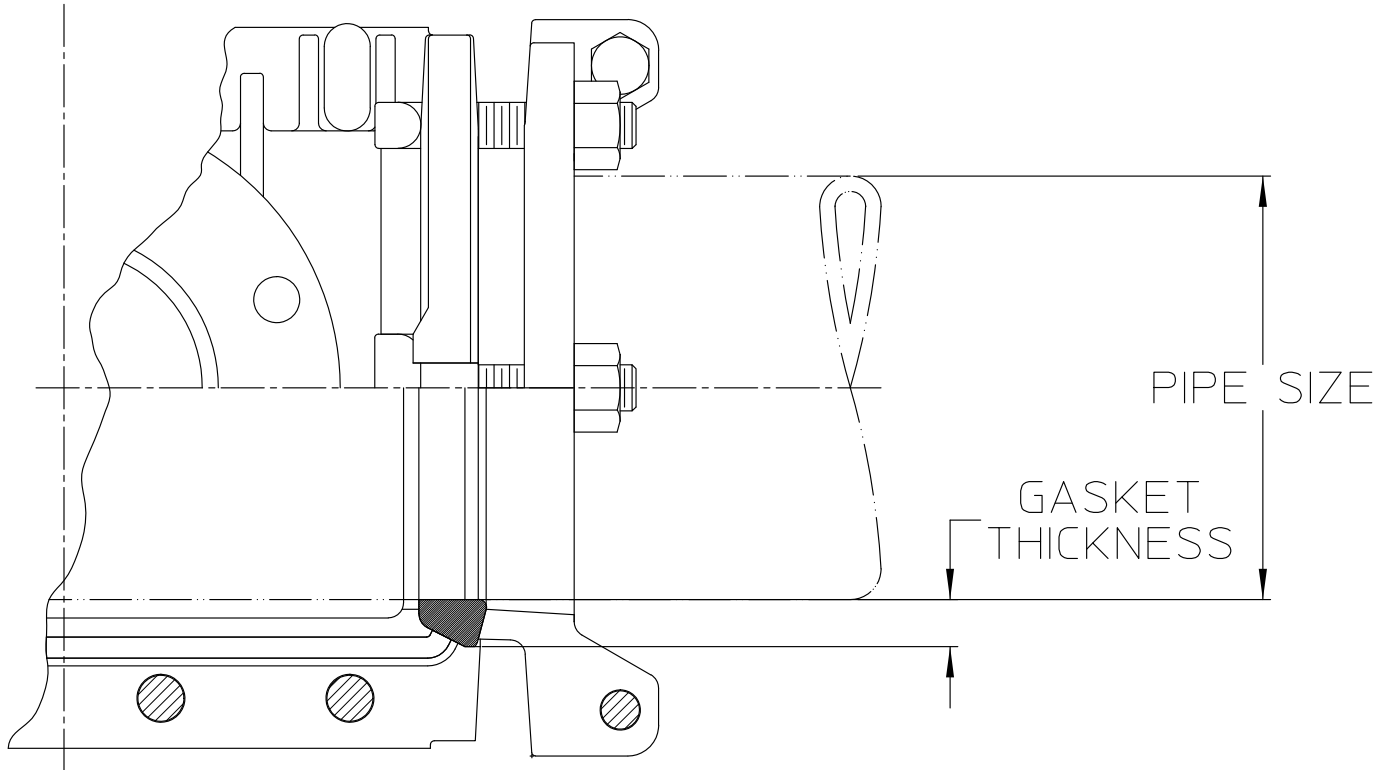

IL1475-2

Nominal Pipe Size	3/4 in. Thick Duck Tip Gasket				5/8 in. Thick Plain Gasket			
	Diameter		Circumference		Diameter		Circumference	
	Minimum	Maximum	Minimum	Maximum	Minimum	Maximum	Minimum	Maximum
4"	4.97	5.30	15.62	16.62	5.30	5.57	16.62	17.50
6"	7.05	7.29	22.12	22.94	7.29	7.60	22.94	23.88
8"	9.22	9.54	29.00	30.00	9.54	9.77	30.00	30.62
10"	11.40	11.90	35.81	37.38	11.90	12.10	37.38	38.06
12"	13.90	14.25	43.69	44.75	14.25	14.50	44.75	45.56



## SERIES 2800 - WEIGHTS

**NOTE:** All weights are in pounds.

Size (Inches)	2800-C for CI	2800-A for A-C
4 x 4	101	106
6 x 4	140	144
6 x 6	144	148
8 x 4	154	160
8 x 6	156	166
8 x 8	165	174
10 x 4	238	257
10 x 6	246	262
10 x 8	255	267
10 x 10	262	276
12 x 4	267	284
12 x 6	271	288
12 x 8	279	293
12 x 10	290	305
12 x 12	301	315
14 x 4	480	-
14 x 6	485	-
14 x 8	495	-
14 x 10	600	-
14 x 12	625	-
14 x 14	645	-
16 x 4	560	-
16 x 6	565	-
16 x 8	580	-
16 x 10	705	-
16 x 12	725	-
16 x 16	751	-
18 x 4	660	-
18 x 6	665	-
18 x 8	675	-
18 x 10	810	-
18 x 12	835	-
18 x 14	940	-
18 x 16	980	-
18 x 18	1010	-

Size (Inches)	2800-C for CI	2800-A for A-C
20 x 4	666	-
20 x 6	671	-
20 x 8	680	-
20 x 10	809	-
20 x 12	824	-
20 x 16	842	-
20 x 18	922	-
20 x 20	950	-
24 x 4	715	-
24 x 6	721	-
24 x 8	880	-
24 x 10	888	-
24 x 12	904	-
24 x 14	1052	-
24 x 16	1075	-
24 x 18	1086	-
24 x 20	1263	-
24 x 24	1312	-

**AMERICAN Flow Control**  
**SERIES 2800 TAPPING SLEEVES**



**SUBMITTAL SHEET**

Sleeve Type							
Series 2800-C for Gray Iron or Ductile Iron Pipe				Series 2800-A for Asbestos Cement (A-C Pipe)			
Qty	Pipe Size	Branch Size	Extra 5/8 in. Thick Gaskets for Pit Cast Pipe		Qty	Pipe Size	Branch Size
			Yes	No			

**AMERICAN Flow Control**  
 American-Darling Valve and Waterous  
 A Division of AMERICAN

**NOTES:**

1. Series 2800-C: 250 psig rated working pressure. Series 2800-A: 200 psig rated working pressure.
2. Series 2800-C sleeves through 16in. are supplied with two 3/4 in. thick gaskets that fit ductile iron and centrifugally cast gray iron pipe, or alternatively two 5/8 in. thick gaskets should be used for pit cast pipe. If there is a doubt about which type of pipe the sleeve will be used with, order 5/8 in. thick gaskets in addition to the 3/4 in. thick gaskets.
3. Series 2800-A sleeves are furnished with both 3/4in. and 5/8in. thick gaskets to fit all sizes of A-C pipe. See 2800-A literature for pipe size ranges that require each size gasket.
4. See separate submittal sheet for tapping valves.

Visit our website at <http://www.american-usa.com/afc>



## Inspection on Delivery

When the shipment arrives, check for shortages or damage.

Any damage or shortage should be reported immediately to the trucker noted on the bill of lading and signed by the driver on your copy.

Carefully unload all tapping sleeves and valves. **DO NOT DROP.**

Check the tapping sleeve pipe size, branch size, specified pipe (A-C, Series 2800-A or iron, Series 2800-C sleeve) and quantity against order specifications. Also check the tapping valve to be sure it conforms to proper specification.

## Storage

When possible, keep the tapping sleeves and valves out of the weather. If stored outside, cover with a waterproof covering.

In cold climates, keep the inside of the tapping sleeves or valves drained of any water to prevent freezing.

## Mechanical Joint End Gaskets

### ***Series 2800-C Sleeve for Iron Pipe***

AFC Series 2800-C mechanical joint tapping sleeves can be used with ductile iron, centrifugally cast gray iron or pit cast pipe. For A-C pipe, use an A-C tapping sleeve.

Two 3/4 in. thick gaskets that fit ductile iron and centrifugally cast gray iron pipe are supplied, or alternatively two 5/8 in. thick gaskets should be used for pit cast pipe. If there is a doubt about which type of pipe the sleeve will be used with, order 5/8 in. thick gaskets in addition to the 3/4 in. thick gaskets.

### ***Series 2800-A Sleeve for Asbestos-Cement (A-C) Pipe***

AFC Series 2800-A mechanical joint tapping sleeves are for use with A-C pipe. Use 3/4 in. thick or 5/8 in. thick gaskets based on the size of pipe sleeve is used on. For iron pipe, use an iron pipe tapping sleeve. See next page for range of pipe sizes with which each size gasket can be used.

# SERIES 2800 - INSTALLATION

## Installation



1. Clean the pipe surface thoroughly to permit a good seal under the end gaskets.
2. Measure pipe O.D. or circumference to be sure of proper gasket size. See tables below:

### Iron Pipe Size Ranges

Nominal Pipe Size	3/4" Thick Gasket				5/8" Thick Gasket			
	Diameter		Circumference		Diameter		Circumference	
	Minimum	Maximum	Minimum	Maximum	Minimum	Maximum	Minimum	Maximum
4"	4.74	4.86	14.88	15.25	4.86	5.06	15.25	15.88
6"	6.84	6.96	21.50	21.88	6.96	7.16	21.88	22.50
8"	8.99	9.11	28.25	28.62	9.11	9.37	28.62	29.44
10"	11.04	11.16	34.69	35.06	11.16	11.44	35.06	35.31
12"	13.14	13.26	41.31	41.69	13.26	13.53	41.69	42.50
14"	15.24	15.36	47.88	48.25	-	-	-	-
16"	17.34	17.46	54.50	54.88	17.46	17.87	54.88	56.12
18"	19.44	19.56	61.07	61.45	-	-	-	-
20"	21.54	21.66	67.67	68.05	-	-	-	-
24"	25.74	25.86	80.86	81.24	-	-	-	-

### Asbestos-Cement (A-C) Pipe Size Ranges

Nominal Pipe Size	3/4" Thick Duck Tip Gasket				5/8" Thick Plain Gasket			
	Diameter		Circumference		Diameter		Circumference	
	Minimum	Maximum	Minimum	Maximum	Minimum	Maximum	Minimum	Maximum
4"	4.97	5.30	15.62	16.62	5.30	5.57	16.62	17.50
6"	7.05	7.29	22.12	22.94	7.29	7.60	22.94	23.88
8"	9.22	9.54	29.00	30.00	9.54	9.77	30.00	30.62
10"	11.40	11.90	35.81	37.38	11.90	12.10	37.38	38.06
12"	13.90	14.25	43.69	44.75	14.25	14.50	44.75	45.56

3. Bolt the sleeve together on the pipe, making sure the inside surfaces of the MJ bell line up at the split line. Tighten the side bolts evenly, working from the center to the ends. After the side bolts are tightened, trim the protruding ends of the side gaskets so they are flush or protruding up to 1/16 in. past the iron surface.
4. Rotate sleeve to desired position.
5. Insert correct end gaskets and check to make sure the beveled ends are lapped together evenly and fit inside the MJ bell. End gasket joint should be located away from the split line of the sleeve. No trimming of end gaskets should be necessary. Lubricate the socket, gasket and pipe O.D. with soapy water or an approved pipe lubricant meeting requirements of AWWA C111.
6. Bolt split glands together, position against gaskets and install bolts. Tighten the bolts alternately (opposite sides) until all are evenly tight. For best results, 90 ft-lbs of bolt torque is recommended.
7. AMERICAN recommends the use of AMERICAN Flow Control Series 2500 tapping valves. Please refer to Section 5A of the AMERICAN Valve and Hydrant Manual for tapping valve installation instructions. In cases where other tapping valve manufacturers are used, please contact that manufacturer for specific tapping valve installation and testing instructions. Applicable tapping sleeve dimensions should be in compliance with the Standard Practice as defined in MSS SP-60. AMERICAN will not be responsible for claims, errors or omissions in documentation provided by other manufacturers.
8. Place the gasket on the tapping valve and bolt the valve to the sleeve. After the valve is bolted securely in place, open the valve fully and observe that the resilient wedge is clear of the waterway. Close the valve completely.
9. Install proper blocking under the valve and behind the sleeve to carry the pipe thrust.
10. Prior to making the tap, test the tapping valve and sleeve as a complete unit by connecting the test pressure to the tap located on the back of the tapping sleeve. **Always test with water.** Test pressure must not exceed the rated working pressure (Series 2800-C: 250 psig and Series 2800-A: 200 psig) of the sleeve and tapping valve. This will point out any leaks or other problems if the sleeve has not been properly installed. Any leaks or other problems must be remedied before the pipe is drilled out. If the sleeve has no test plug, test the sleeve and valve assembly through the test plug in the valve bonnet with the wedge in the open position.



## SERIES 2800 - INSTALLATION



**WARNING: USE ONLY WATER TO TEST TAPPING SLEEVE AND TAPPING VALVE ASSEMBLY. UNDER NO CIRCUMSTANCES SHOULD AIR EVER BE USED TO CONDUCT THIS TEST. TESTING WITH AIR MAY RESULT IN SERIOUS INJURY OR DEATH.**

11. Attach the tapping machine to the valve, making sure the machine is centered and square with the end of the valve to assure straight travel of the cutter through the valve. With the tapping machine attached and the cutter fully retracted, check to be sure the valve can be closed completely, then open the valve fully.
12. Final check before boring: Open the valve fully. Make sure the cutter does not damage the gate or seats of the valve (or touch any interior surface of the resilient wedge tapping valve). If any resistance is felt when hand feeding the cutter into position, stop and correct before making the tap.

**SERIES 2800-C PARTS LIST, 4" - 12" & 16" SIZES  
FOR USE WITH GRAY IRON OR DUCTILE IRON PIPE**

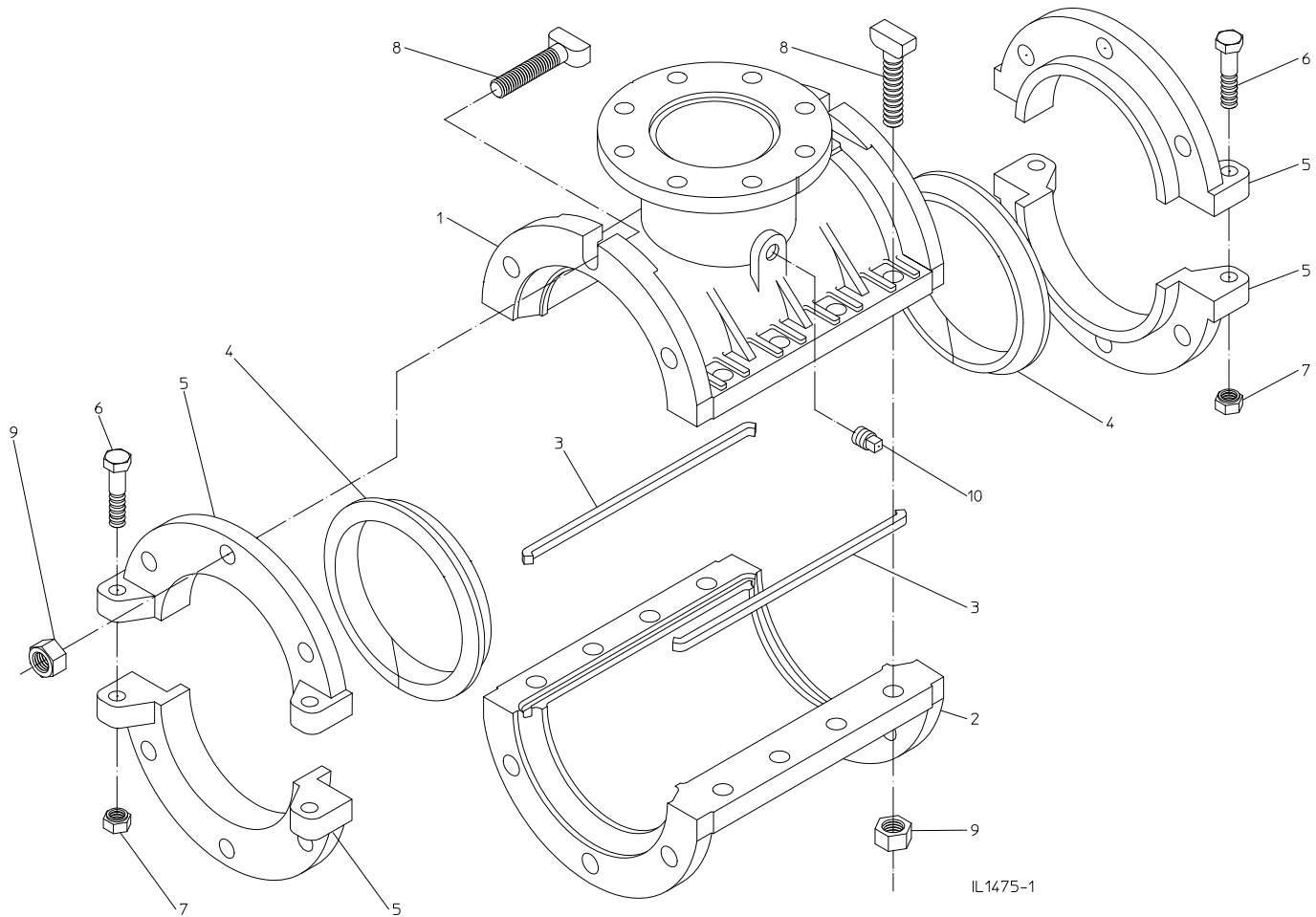

IL1475-1

Ref No.	Description	Material	Quantity					
			4"	6"	8"	10"	12"	16"
1	Tapping Sleeve Front	Ductile Iron ASTM A536 Grade 65-45-12	1	1	1	1	1	1
2	Tapping Sleeve Back	Ductile Iron ASTM A536 Grade 65-45-12	1	1	1	1	1	1
3	MJ Side Gasket	Rubber	2	2	2	2	2	2
4	MJ End Gasket	Rubber	2	2	2	2	2	2
5	MJ Split Gland Half	Ductile Iron ASTM A536 Grade 65-45-12	4	4	4	4	4	4
6	Hex Head Bolt, 5/8" - 11 x 2 3/4"	Zinc Plated Steel	4	4	-	4	-	-
6	Hex Head Bolt, 5/8" - 11 x 3"	Zinc Plated Steel	-	-	-	-	-	4
6	Hex Head Bolt, 1/2" - 12 x 3 1/2"	Zinc Plated Steel	-	-	-	-	4	-
6	Hex Head Bolt, 1/2" - 13 x 3"	Zinc Plated Steel	-	-	4	-	-	-
7	Hex Nut, 5/8" - 11	Zinc Plated Steel	4	4	-	4	-	4
7	Hex Nut, 1/2" - 13	Zinc Plated Steel	-	-	4	-	4	-
8	T-Head Bolt, 3/4" - 10	Cor-Ten Steel	14	20	20	26	26	38
9	T-Head Nut, 3/4" - 10	Cor-Ten Steel	14	20	20	26	26	38
10	Square Head Pipe Plug, 1/2" NPT	Bronze	1	1	1	1	1	1

**SERIES 2800-C PARTS LIST, 16" X 16" SIZE  
FOR USE WITH GRAY IRON OR DUCTILE IRON PIPE**

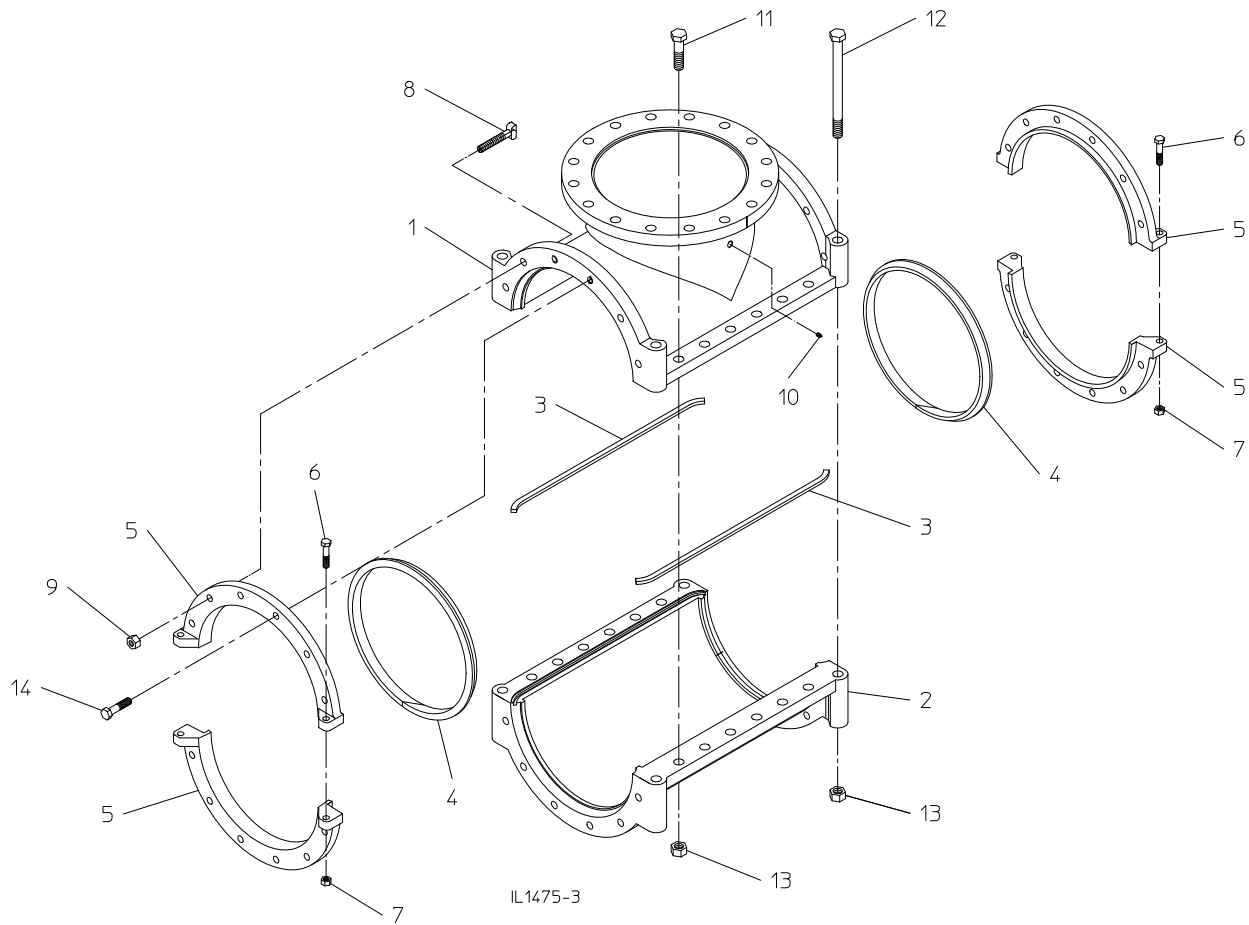

Ref No.	Description	Material	Quantity
1	Tapping Sleeve Front	Cast Ductile Iron	1
2	Tapping Sleeve Back	Cast Ductile Iron	1
3	MJ Side Gasket	Rubber	2
4	MJ End Gasket	Rubber	2
5	MJ Split Gland Half	Cast Ductile Iron	4
6	Hex Head Bolt, 5/8" - 11 x 3"	Zinc Plated Steel	4
7	Hex Nut, 5/8" - 11	Zinc Plated Steel	4
8	T-Head Bolt, 3/4" - 10 x 4-1/2"	Cor-Ten Steel	20
9	T-Head Nut, 3/4" - 10	Cor-Ten Steel	20
10	Square Head Pipe Plug, 1/2" NPT	Bronze	1
11	Hex Head Bolt, 1" - 8 x 4"	Zinc Plated	12
12	Hex Head Bolt, 1" - 8 x 13	Zinc Plated Steel	4
13	Hex Nut, 1" - 8	Zinc Plated Steel	16
14	Hex Head Bolt, 3/4" - 10 x 3-1/4"	Cor-Ten Steel	4

## SERIES 2800-C PARTS LIST, 14" & 18"-24" SIZES FOR USE WITH GRAY IRON OR DUCTILE IRON PIPE

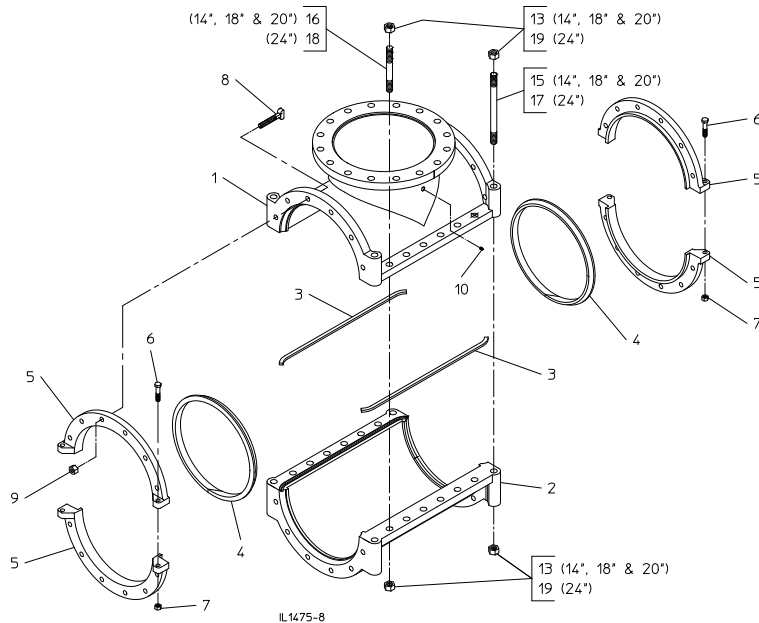

Ref No.	Description	Material	Quantity			
			14"	18"	20"	24"
1	Tapping Sleeve Front	Cast Ductile Iron	1	1	1	1
2	Tapping Sleeve Back	Cast Ductile Iron	1	1	1	1
3	MJ Side Gasket	Rubber	2	2	2	2
4	MJ End Gasket	Rubber	2	2	2	2
5	MJ Split Gland Half	Cast Ductile Iron	4	4	4	4
6	Hex Head Bolt, 3/4" - 10	Zinc Plated Steel	4	4	4	4
7	Hex Nut, 3/4" - 10	Zinc Plated Steel	4	4	4	4
8	T-Head Bolt, 3/4" - 10	Cor-Ten Steel	20	24	28	32
9	T-Head Nut, 3/4" - 10	Cor-Ten Steel	20	24	28	32
10	Square Head Pipe Plug, 1/2" NPT	Stainless Steel	1	1	1	1
13	Hex Nut, 1" - 8	Zinc Plated Steel	See Tables	See Tables	See Tables	-
15	Stud, 1" - 8	Zinc Plated Steel	4	4	4	-
16	Stud, 1" - 8	Zinc Plated Steel	See Tables	See Tables	See Tables	-
17	Stud, 1-1/4" - 8	Zinc Plated Steel	-	-	-	4
18	Stud, 1-1/4" - 8	Zinc Plated Steel	-	-	-	See Tables
19	Hex Nut, 1-1/4" - 8	Zinc Plated Steel	-	-	-	Sees Tables

Sleeve Size (Pipe x Branch)	14x4	14x6	14x8	14x10	14x12	14x14	18x4	18x6	18x8	18x10	18x12
Ref. No. 16	8	8	8	8	10	10	6	6	8	8	8
Ref. No. 13	24	24	24	24	28	28	14	14	16	16	16

Sleeve Size (Pipe x Branch)	18x14	18x16	18x18	20x4	20x6	20x8	20x10	20x12	20x14	20x16	20x18
Ref. No. 16	12	12	12	8	8	8	8	12	12	12	14
Ref. No. 13	20	20	20	16	16	16	16	20	20	20	22

Sleeve Size (Pipe x Branch)	20x20	24x4	24x6	24x8	24x10	24x12	24x14	24x16	24x18	24x20	24x24
Ref. No. 16 or 18	14	6	6	8	8	8	12	12	12	14	14
Ref. No. 13 or 19	22	14	14	16	16	16	32	32	32	36	36

**SERIES 2800-A PARTS LIST, 4" - 12" SIZES  
FOR USE WITH ASBESTOS-CEMENT (A-C) PIPE**

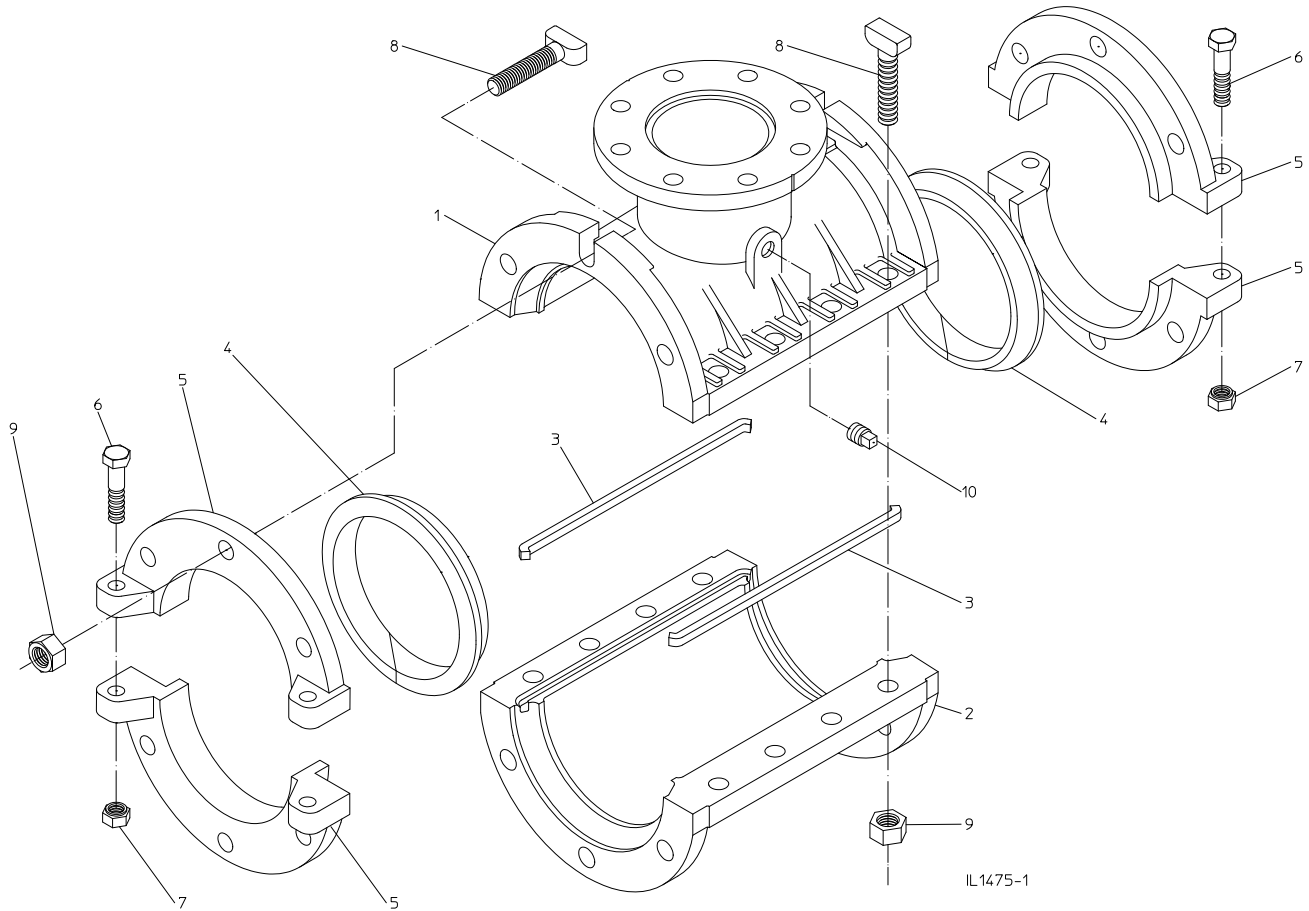

Ref No.	Description	Material	Quantity				
			4"	6"	8"	10"	12"
1	Tapping Sleeve Front	Cast Ductile Iron	1	1	1	1	1
2	Tapping Sleeve Back	Cast Ductile Iron	1	1	1	1	1
3	MJ Side Gasket	Rubber	2	2	2	2	2
4	MJ End Gasket	Rubber	2	2	2	2	2
5	MJ Split Gland Half	Cast Ductile Iron	4	4	4	4	4
6	Hex Head Bolt, 5/8" - 11 x 3"	Zinc Plated Steel	4	4	-	4	-
6	Hex Head Bolt, 1/2" - 12 x 3 1/2"	Zinc Plated Steel	-	-	-	-	4
6	Hex Head Bolt, 1/2" - 13 x 3"	Zinc Plated Steel	-	-	4	-	-
7	Hex Nut, 5/8" - 11	Zinc Plated Steel	4	4	-	4	-
7	Hex Nut, 1/2" - 13	Zinc Plated Steel	-	-	4	-	4
8	T-Head Bolt, 3/4" - 10	Cor-Ten Steel	14	20	20	26	26
9	T-Head Nut, 3/4" - 10	Cor-Ten Steel	14	20	20	26	26
10	Square Head Pipe Plug, 1/2" NPT	Bronze	1	1	1	1	1



# AMERICAN

FLOW CONTROL

**THE RIGHT WAY**

**AMERICAN Flow Control**

P.O. Box 2727  
Birmingham, AL 35202-2727  
Phone: 800-326-8051  
Fax: 800-610-3569  
Email: afcsales@american-usa.com

**Waterous Company**

125 Hardman Avenue South  
South St. Paul, MN 55075-2421  
Phone: 888-266-3686  
Fax: 800-601-2809  
Email: afcsales@american-usa.com

**[WWW.AMERICAN-USA.COM](http://WWW.AMERICAN-USA.COM)**



Product literature may become outdated. AMERICAN is not responsible for out-of-date information, errors or omissions.  
Please contact AMERICAN for the most current product information.